

- a. 16mm (5/8")
- b. 25mm (1")
- c. 29mm (1 5/32")
- d. 28mm (1 1/8")

Not to scale/Nicht maßstabsgetreu/  
Pas à l'échelle/Non in scala/No a escala/  
Niet op schaal/Não está à escala /  
не в масштабе/Не в скали/Ölçekli değildir

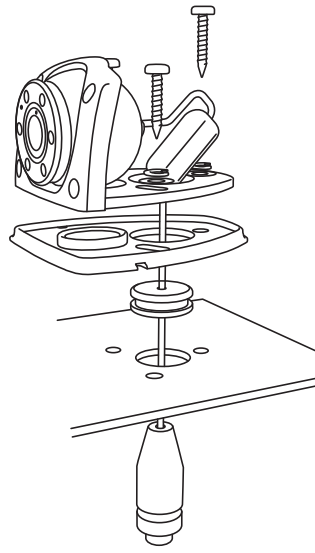

③ \*Adhesive/Adhésif/Klebstoff/Adesivo  
Adhesivo/Lijm/Adesivo/клей/Spoiwo/Yapışkan

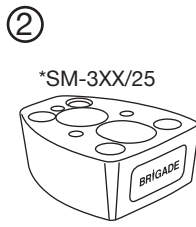
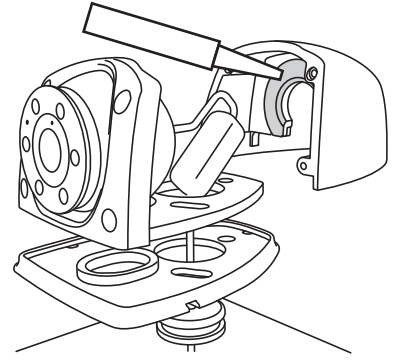

\*Optional/Optionnel/Optional/Opzionale/Opcional/Optional/Опционал/необязательный/Опционал/İsteğe bağlı

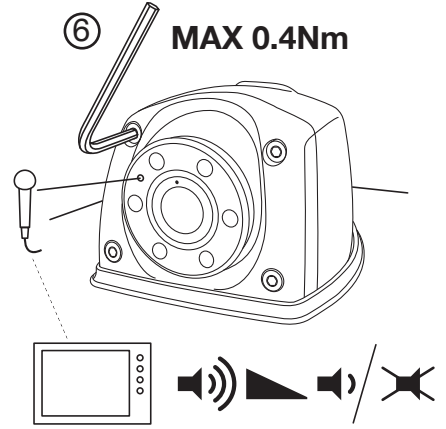
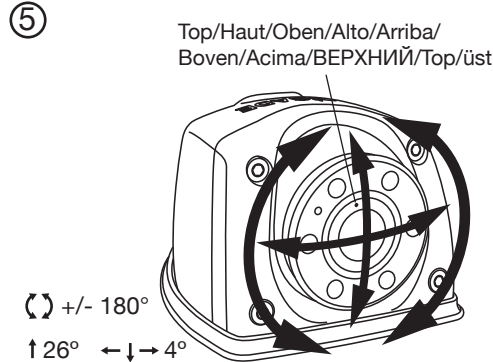
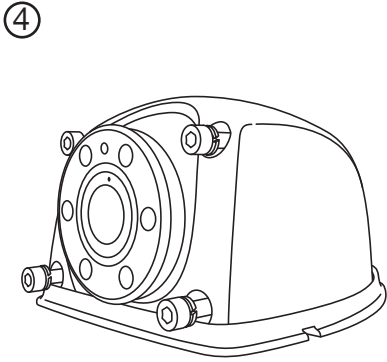

Part Number: 7176

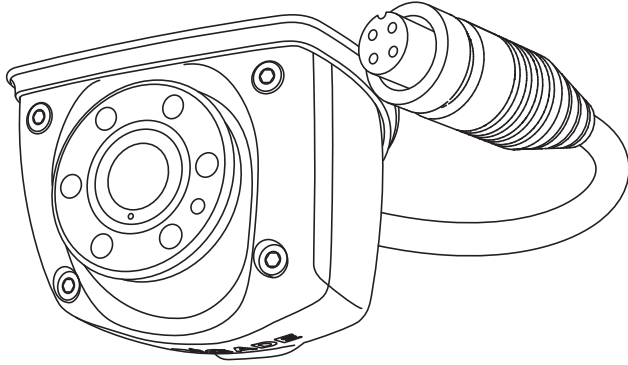

Quick start installation instructions  
Guide de démarrage rapide  
Anleitung Schnellstart-Installation  
Istruzioni installazione veloce  
Instrucciones de instalación de inicio rápido  
Snel starten installatie-instructies  
Pykovoдство по быстрой настройке  
Instruções de instalação de início rápido  
Skrócona instrukcja montażu  
Hızlı Kurulum yönergeleri

**VBV-31XXC**

**BRIGADE**

TECHNISCHE DATEN - VBV-31XXC KAMERA	
BILDSEKTOR	CMOS
TV-NORM	VBV-31XXC - AHD 2.0 (1080P - 25fps)
BILDELEMENTE	VBV-31X1C - AHD 2.0 (1080P - 30fps)
BILDSENSOR DIAGONALE	1920(H) x 1080(V)
SYNCHRONISIERUNG	INTERNAL
HORIZONTALE AUFLÖSUNG	900 TV-ZEILEN
NOTWENDIGE HELLEKTEIT	0 LUX (IR LED BELEUCHTUNG INTEGRIERT)
AUDIO	INTEGRIERTES MIKROFON
VERSORGUNGSSPANNUNG	12 Vdc ± 2 Vdc
LEISTUNGS-AUFNAHME	1.6 W (für 14 Vdc)
STROMVERBRAUCH	112 mA (für 14 Vdc)
IP RATINGS	KAMERA IP69K / ANSCHLUSS IP67
BETRIEBSTEMPERATUR	-30 - +70°C / -22 - +158°F
LAGERTEMPERATUR	-40 - +85°C / -40 - +185°F
GEWICHT	160g (0.35lbs)
ABMESSUNGEN (B x H x T)	57 x 42 x 70mm (2.2 x 1.7 x 2.8 Zoll)

SPECIFICATIONS - VBV-31XXC CAMERA	
PICK-UP DEVICE	CMOS
TV SYSTEM	VBV-31XXC - AHD 2.0 (1080P - 25fps)
PICTURE ELEMENTS	VBV-31X1C - AHD 2.0 (1080P - 30fps)
IMAGE SIZE	1920(H) x 1080(V)
SYNCHRONISATION	INTERNAL
HORIZONTAL RESOLUTION	900 TV LINES
REQUIRED ILLUMINATION	0 LUX (IR LED ILLUMINATION INTEGATED)
AUDIO	INTEGRATED MICROPHONE
POWER SUPPLY	12 Vdc ± 2 Vdc
POWER CONSUMPTION	1.6W (at 14 Vdc)
CURRENT CONSUMPTION	112mA (at 14 Vdc)
LENS ANGLE (H), (V), (D)	130°, 70°, 151° ±5°
IP RATINGS	CAMERA IP69K / CONNECTOR IP67
OPERATING TEMPERATURE	-30 - +70°C / -22 - +158°F
STORAGE TEMPERATURE	-40 - +85°C / -40 - +185°F
WEIGHT	160g (0.35lbs)
DIMENSIONS (W x H x D)	57 x 42 x 70mm (2.2 x 1.7 x 2.8 inches)

**IT SPECIFICHE TECNICHE - TELECAMERA VBV-30XXC**

SENSORE DI IMMAGINE	CMOS
STANDARD TV	VBV-31X0C - AHD 2.0 (1080P - 25fps) VBV-31X1C - AHD 2.0 (1080P - 30fps)
ELEMENTI IMMAGINE	1920(H) x 1080(V)
DIMENSIONE IMMAGINE	1/2.9 pollice
SINCRONIZZAZIONE	INTERNA
RISOLUZIONE ORIZZONTALE	900 LINEE TV
ILLUMINAZIONE RICHIESTA	0 LUX (LED A INFRAROSSO INTEGRATI)
AUDIO	MICROFONO INTEGRATO
ALIMENTAZIONE	12 Vdc ± 2 Vdc
CONSUMO DI POTENZA	1,6W (a 14 Vdc)
CONSUMO DI CORRENTE	112mA (a 14 Vdc)
ANGOLOLENTE (D), (O), (V)	130°, 70°, 151° ±5°
VALUTAZIONE IP	TELECAMERA IP69K / CONNETTORE IP67
TEMPERATURA DI FUNZIONAMENTO	-30 - +70°C / -22 - +158°F
TEMPERATURA DI STOCCAGGIO	-40 - +85°C / -40 - +185°F
PESO	160g (0.35lbs)
DIMENSIONI (L x A x P)	57 x 42 x 70mm (2.2 x 1.7 x 2.8 pollici)

**PT ESPECIFICAÇÕES - CÂMERA VBV-30XXC**

DISPOSITIVO DE CAPTAÇÃO	CMOS
SISTEMA DE TV	VBV-31X0C - AHD 2.0 (1080P - 25fps) VBV-31X1C - AHD 2.0 (1080P - 30fps)
ELEMENTOS DE IMAGEM	1920(H) x 1080(V)
TAMANHO DA IMAGEM	1/2.9 polegada
SINCRONIZAÇÃO	INTERNA
RESOLUÇÃO HORIZONTAL	900 LINHAS DE TV
ILUMINAÇÃO NECESSÁRIA	0 LUX (ILUMINAÇÃO INTEGRADA LED IV)
ÁUDIO	MICROFONE INTEGRADO
FONTE DE ALIMENTAÇÃO	12 Vdc ± 2 Vdc
CONSUMO DE ENERGIA	1,6 W (em 14 Vdc)
CONSUMO DE CORRENTE	112mA (em 14 Vdc)
ÂNGULO DALENTE (H), (V), (P)	130°, 70°, 151° ±5°
IP RATINGS	CÂMERA IP69K / CONECTOR IP67
TEMPERATURA OPERACIONAL	-30 - +70°C / -22 - +158°F
TEMPERATURA DE ARMAZENAMENTO	-40 - +85°C / -40 - +185°F
PESO	160 g (0.35lbs)
DIMENSÕES (L x A x P)	57 x 42 x 70 mm (2.2 x 1.7 x 2.8 polegadas)

**ES ESPECIFICACIONES - CÁMARA VBV-30XXC**

DISPOSITIVO DE CAPTACIÓN	CMOS
SISTEMA DE TV	VBV-31X0C - AHD 2.0 (1080P - 25fps) VBV-31X1C - AHD 2.0 (1080P - 30fps)
ELEMENTOS DE IMAGEN	1920(H) x 1080(V)
TAMAÑO DE IMAGEN	1/2.9 pulgada
SINCRONIZACIONES	INTERNAS
RESOLUCIÓN HORIZONTAL	900 LÍNEAS DE TV
ILUMINACIÓN REQUERIDA	0LUX (LED INFRARROJOS INTEGRADOS)
AUDIO	MICRÓFONO INTEGRADO
SUMINISTRO DE VOLTAGE	12 Vdc ± 2 Vdc
CONSUMO DE POTENCIA	1,6W (en 14 Vdc)
CONSUMO DE CORRIENTE	112mA (en 14 Vdc)
ÁNGULO DELENTE (H),(V),(D)	130°, 70°, 151° ±5°
CLASIFICACIÓN IP	CÁMARA IP69K / CONECTOR IP67
TEMPERATURA DE TRABAJO	-30 - +70°C / -22 - +158°F
TEMPERATURA DE ALMACENAMIENTO	-40 - +85°C / -40 - +185°F
PESO	160g (0.35lbs)
DIMENSIONES (An x Al x P)	57 x 42 x 70mm (2.2 x 1.7 x 2.8 inches)

**PL DANE TECHNICZNE - VBV-30XXC CAMERA**

TYP PRZETWORNIKA	CMOS
SYSTEM TV	VBV-31X0C - AHD 2.0 (1080P - 25fps) VBV-31X1C - AHD 2.0 (1080P - 30fps)
LICZBA PIXELI	1920 (Po) x 1080 (Pi)
ROZMIAR MATRYCY	1/2.9 cal
SYNCHRONIZACJA	wewnętrzny
ROZDZIELCZOŚĆ HORYZONTALNA	900 LINIE TV
CZUŁOŚĆ KAMERY	0 minimalna Lux
AUDIO	wbudowany mikrofon
ZASILANIE	12 Vdc ± 2 Vdc
POBÓR MOCY	1,6W (at 14 Vdc)
POBÓR PRĄDU	112mA (at 14 Vdc)
KĄT WIDZENIA	130°, 70°, 151° ±5°
IP RATINGS	CAMERA IP69K / ZŁĄCZE IP67
TEMPERATURA PRACY	-30 Do +70°C / -22 Do +158°F
TEMPERATURA PRZECHOWYWANIA	-40 Do +85°C / -40 Do +185°F
WAGA	160g (0.35lbs)
WYMIARY (S x W x G)	57 x 42 x 70 mm (2.2 x 1.7 x 2.8 cale)

**NL SPECIFICATIES - VBV-30XXC CAMERA**

OPNAME APPARAAT	CMOS
TV-SYSTEEM	VBV-31X0C - AHD 2.0 (1080P - 25fps) VBV-31X1C - AHD 2.0 (1080P - 30fps)
BEELDELEMENTEN	1920(H) x 1080(V)
BEELDGROOTTE	1/2.9 inch
SYNCHRONISATIE	INTERN
HORIZONTALE RESOLUTIE	900 TV-LIJNEN
VEREISTE VERLICHTING	0 LUX (IR LED VERLICHTING GEÏNTEGREERDE)
AUDIO	MICROFOON GEÏNTEGREERDE
VOEDINGSSPANNING	12 Vdc ± 2 Vdc
STROOMVERBRUIK	1,6W (op 14 Vdc)
HUIDIG VERBRUIK	112mA (op 14 Vdc)
LENSHOEK (H), (V), (D)	130°, 70°, 151° ±5°
IP BEOORDELING	CAMERA IP69K / CONNECTOR IP67
WERKTEMPERATUUR	-30 - +70°C / -22 - +158°F
OPSLAGTEMPERATUUR	-40 - +85°C / -40 - +185°F
GEWICHT	160g (0.35lbs)
AFMETINGEN (B X H X D)	57 x 42 x 70mm (2.2 x 1.7 x 2.8 inch)

**FR CARACTÉRISTIQUES TECHNIQUES - VBV-30XXC CAMÉRA**

DISPOSITIF DE CAPTURE	CMOS
SYSTÈME TV	VBV-31X0C - AHD 2.0 (1080P - 25fps) VBV-31X1C - AHD 2.0 (1080P - 30fps)
ÉLÉMENTS DE L'IMAGE	1920(H) x 1080(V)
DIMENSION DE L'IMAGE	1/2.9 pouce
SYNCHRONISATION	INTERNE
DÉFINITION HORIZONTALE	900 LIGNES TV
ÉCLAIREMENT NÉCESSAIRE	0 LUX (LED INFRAROUGE INTÉGRÉE)
AUDIO	MICROPHONE INTÉGRÉE
ALIMENTATION	12 Vdc ± 2 Vdc
PUISSANCE CONSOMMÉE	1,6 W (à 14 Vdc)
CONSOMMATION EN COURANT	112mA (à 14 Vdc)
ANGLE D'OBJECTIF (H), (V), (P)	130°, 70°, 151° ±5°
CLASSEMENT IP	CAMÉRA IP69K / CONNECTEUR IP67
TEMPÉRATURE DE FONCTIONNEMENT	-30 - +70°C / -22 - +158°F
TEMPÉRATURE DE STOCKAGE	-40 - +85°C / -40 - +185°F
POIDS	160g (0.35lbs)
DIMENSIONS (L x P x H)	57 x 42 x 70mm (2.2 x 1.7 x 2.8 pouces)

**RU технические условия - КАМЕРА VBV-30XXC**

ПРИЕМНОЕ УСТРОЙСТВО	CMOS
ТЕЛЕСИСТЕМА	VBV-31X0C - AHD 2.0 (1080P - 25fps) VBV-31X1C - AHD 2.0 (1080P - 30fps)
ЭЛЕМЕНТЫ ИЗОБРАЖЕНИЯ	1920 (Г) x 1080 (В)
РАЗМЕР ИЗОБРАЖЕНИЯ	1/2.9 дюйма
СИНХРОНИЗАЦИЯ	ВНУТРЕННЯЯ
РАЗРЕШАЮЩАЯ СПОСОБНОСТЬ	900 ТВ линии
ПО ГОРИЗОНТАЛИ	0 ЛЮКС (ВСТРОЕННАЯ ИНФРАКРАСНАЯ СВЕТОДИОДНАЯ ПОДСВЕТКА)
ТРЕБУЕМАЯ ПОДСВЕТКА	ВСТРОЕННЫЙ МИКРОФОН
АУДИО	12 В ПОСТОЯННОГО ТОКА ± 2 В
ИСТОЧНИК ПИТАНИЯ	1.6 Вт (ПРИ 14 В ПОСТОЯННОГО ТОКА)
ЭНЕРГОПОТРЕБЛЕНИЕ	112 мА (ПРИ 14 В ПОСТОЯННОГО ТОКА)
ПОТРЕБЛЕНИЕ ТОКА	130°, 70°, 151° ±5°
УГОЛ ЛИНЗЫ (Г), (В), (ГЛБ.)	РЕГУЛИРОВКА УГЛА ПОВОРОТА
РЕГУЛИРОВКА УГЛА ПОВОРОТА	IP-РЕЙТИНГ
IP-РЕЙТИНГ	КАМЕРА IP69K / КОННЕКТОР IP67
РАБОЧАЯ ТЕМПЕРАТУРА	-30 - +70°C / -22 - +158°F
ТЕМПЕРАТУРА ХРАНЕНИЯ	-40 - +85°C / -40 - +185°F
МАССА	160 г (0.35 фунты)
РАЗМЕРЫ (Ш x В x Г)	57 x 42 x 70 мм (2.2 x 1.7 x 2.8 дюймов)

**TR ÖZELLİKLER - VBV-30XXC CAMERA**

ALGILAMA BİRİMİ	CMOS
TV SİSTEMİ	VBV-31X0C - AHD 2.0 (1080P - 25fps) VBV-31X1C - AHD 2.0 (1080P - 30fps)
RESİM ÖGELERİ	1920 (Y) x 1080 (D)
GÖRÜNTÜ EBADI	1/2.9 inç
SENKRONİZASYON	dahili
YATAY ÇÖZÜNÜRLÜK	900 TV ÇİZGİSİ
GEREKLİ AYDINLANMA	0 (IR illumination integrated)
GÜÇ KAYNAĞI	12 Vdc ± 2 Vdc
GÜÇ SARFI	1.6W (at 14 Vdc)
ÇEKİTİĞİ AKIM	112mA (at 14 Vdc)
MERCEK AÇISI	130°, 70°, 151° ±5°
IP RATINGS	CAMERA IP69K / KONNEKTÖR IP67
ÇALIŞMA ORTAM SICAKLIĞI	-30°C // +70°C/-22°F // +158°F
DEPOLAMA SICAKLIĞI	-40°C // +85°C/-40°F // +185°F
AĞIRLIK	160g (0.35lbs)
EBATLAR (G x Y x D)	57 x 42 x 70 mm (2.2 x 1.7 x 2.8 inç)